

Materials and Features

- Ductile iron GGG50 material with FBE coated
- EPDM Gasket
- Galvanized steel bolts & nuts, dacromet is available
- PN10, PN16, PN25 working pressure

Fig.DJ

Item No.	Parts Name	Material
1	Flange	Ductile Iron
2	Flange	Ductile Iron
3	Gland	Ductile Iron
4	Gasket	EPDM
5	Stud	Galvanized Steel
6	Cap	Plastic
7	Washer	Galvanized Steel
8	Nut	Galvanized Steel

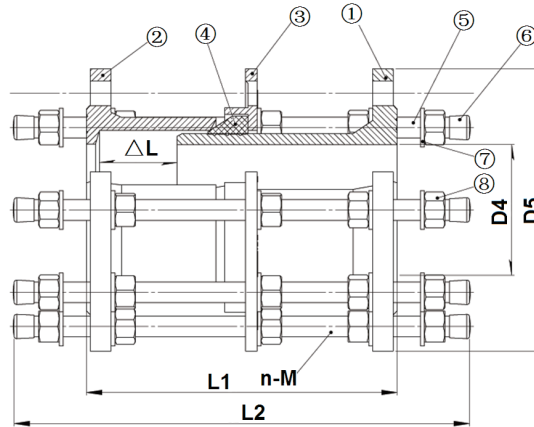

Dimensions (mm)

DN	ΔL	PN10					PN16					PN25				
		L1	D5	D4	n-m	Flange thickness	L1	D5	D4	n-m	Flange thickness	L1	D5	D4	n-m	Flange thickness
40	50	210	145	110	M16*310* 4	16+3	210	145	110	M16*310* 4	16+3	210	145	110	M16*310* 4	16+3
50	50	215	165	125	M16*330* 4	16+3	215	165	125	M16*330* 4	16+3	215	165	125	M16*340* 4	16+3
60	50	215	175	135	M16*330* 4	16+3	215	175	135	M16*330* 4	16+3	215	175	135	M16*330* 4	16+3
65	50	215	185	145	M16*330* 4	16+3	215	185	145	M16*330* 4	16+3	215	185	145	M16*340* 4	16+3
80	50	225	200	160	M16*340* 8	16+3	225	200	160	M16*340* 8	16+3	225	200	160	M16*340* 8	16+3
100	50	225	220	180	M16*340* 8	16+3	225	220	180	M16*340* 8	16+3	225	235	190	M20*370* 8	16+3
125	50	225	250	210	M16*340* 8	16+3	225	250	210	M16*340* 8	16+3	225	270	220	M24*380* 8	16+3
150	50	225	285	240	M20*350* 8	16+3	225	285	240	M20*350* 8	16+3	225	300	250	M24*380* 8	16+3
200	50	235	340	295	M20*380* 8	16+3	235	340	295	M20*380* 12	16+3	240	360	310	M24*400* 12	19+3
250	50	250	400	350	M20*380* 12	19+3	250	400	350	M24*380* 12	19+3	250	425	370	M27*450* 12	21+3
300	50	265	455	400	M20*410* 12	20.5+3	265	455	410	M24*410* 12	20.5+3	270	485	430	M27*460* 16	24+3
350	50	265	505	460	M20*410* 16	20.5+3	265	520	470	M24*410* 16	22.5+3	270	555	490	M30*470* 16	27+3
400	50	275	565	515	M24*450* 16	20.5+3	275	580	525	M27*450* 16	24+3	280	620	550	M33*500* 16	29+3
450	50	295	615	565	M24*450* 20	21.5+3	295	640	585	M27*450* 20	26+3	300	670	600	M33*500* 20	31+3
500	50	295	670	620	M24*450* 20	22.5+3	295	715	650	M30*460* 20	27.5+3	300	730	660	M33*500* 20	32+3
600	50	315	780	725	M27*480* 20	25+3	315	840	770	M33*500* 20	31+3	320	845	770	M36*560* 20	38+3
700	50	325	895	840	M27*480* 24	27.5+3	325	910	840	M33*500* 24	34.5+3	330	960	875	M39*570* 24	43+3
800	50	340	1015	950	M30*500* 24	30+3	340	1025	950	M36*530* 24	38+3	350	1085	990	M45*620* 24	49+3
900	50	350	1115	1050	M30*500* 28	32.5+3	350	1125	1050	M36*530* 28	41.5+3	360	1185	1090	M45*620* 28	52+3
1000	50	360	1230	1160	M33*545* 28	35+3	360	1255	1170	M39*570* 28	45+3	370	1320	1210	M52*660* 28	57+3
1200	50	370	1455	1380	M36*580* 32	40+3	370	1485	1390	M45*620* 32	52+3	380	1530	1420	M52*750* 32	65+3